

INVITATION TO THE IN HOUSE SHOW

October 06 – 08, 2011 | Showroom Nürtingen, Germany

From CAD to finished furniture
IN ONLY 20 MINUTES



LIGNA NEWS
 in daily operation



PRO-MASTER 7225
 Strong. Flexible. Dynamic.



CONTRIGA
 Powerful. Innovative. Faster.



CUT 6120
 Compact. Efficient. Precise.

A WARM WELCOME to HOLZ-HER!

This year's in house show focuses on live presentations of the best woodworking machinery available. See the fully integrated manufacturing process starting with CAD-software and ending up with a finished fixture in 20 minutes or less. The networked machinery ensures a most efficient production and high proceeds. Use the chance to see all highlights from the LIGNA show performing live!

We are looking forward to seeing you! For more information or to enrol for the in-house-show call +49 (0) 7022 702 216.

Best regards

Frank Epple, CEO

Robert Terzer, Head of Sales

Efficient and precise cutting

- Perfect cutting results
- Sophisticated optimizing software
- Ideal cutting cycles

Intelligent edge banding

- Push button program selection
- Also fully automated via barcode

Perfect flow of data

- Information for programs via Data-Matrix-Barcode

CabinetControl

- Fixtures and cabinets by mouse click
- Cutting lists and CNC-programs are generated automatically

Real CNC performance

- Automated program fetch via barcode
- Variable programming using CAMPUS-Software
- Perfect routing results

DONE IN 20 MINUTES

Programming – Cutting – Edge banding – CNC-machining



SAWS

Pressure beam saws

HOLZ-HER pressure beam saws open new dimensions for efficient and precise cutting of different materials.



- Highest material yield results from the integrated optimizing software
- Short learning curve through easy understandable display
- Perfected 3-D display incl. information on cuts and material flow
- Ideal panel- and drop-management

HOLZ-HER is setting the standard

- Hardened linear guide ways in all moving axes
- High productivity through strong, welded machine frame
- Precision fence for precision cuts
- Air-cushion tables and air-cushions along cutting line (standard on most models)



CUT 6120

- Compact dimensions – maximum performance
- Optional postforming scoring saw
- Air cushion on tables and along cutting line

CUT 6010

- Efficient and precise cutting
- Forward and reverse speed variable up to 60 m/min.
- Reliability and ease of use

CUT 6210

- The measuring pole for precision and capacity
- Highest feed- and positioning speeds
- Can be configured individually – even left- and right handed machines

Cutting perfection
from HOLZ-HER



LOADING AND HANDLING SYSTEMS

for customized and economical production

The requirements of your clients have changed. In the modern society, influenced from many cultures, you will find an enormous sense of style variety. Customized solutions, which respect the peoples live style, is the force of the craft sector. Cost effective operation with small lot sizes is a must for the industry as well. A big variety of designs, colour and

material selections is imposing every company the problem of storing and handling those materials. HOLZ-HER is here as well your qualified partner and pioneer for innovative solutions in the field of fully automated handling of panels with extreme saving potentials. Benefit from our know-how and make your production more profitable.

Dynamic loading

for pressure beam saws and CNC

- Short cycle times
- High storing capacity by means of intelligent sorting
- Reduction of warehouse charges
- Current inventory control at any time

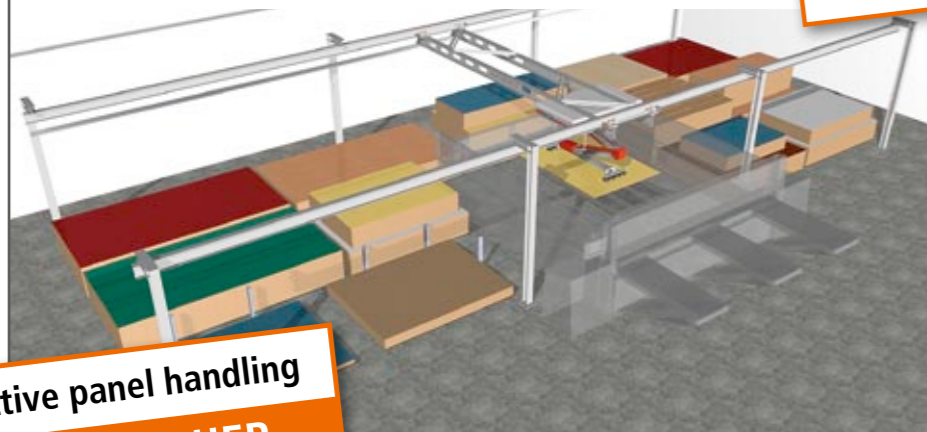

Effective panel handling
from HOLZ-HER

Ask us for the automation
potential in your company!

More informations:
www.automatisierung.holzher.com

Intelligent return system

for HOLZ-HER edge bander

- With turning device 90°/180°
- Stacking and nesting
- For higher efficiency



SAWING

Vertical panel saws

Benefit from more than 50 years of HOLZ-HER experience in vertical sawing. High performance in a small space.

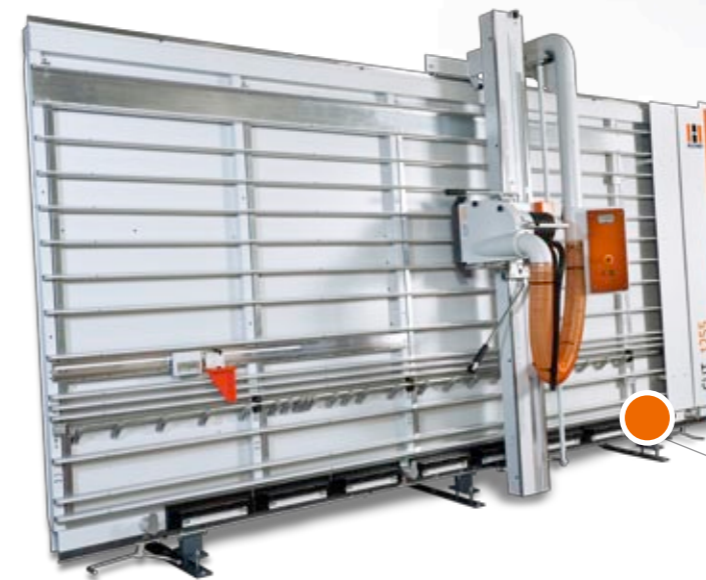

CUT 1255

- Big power vertically standing
- Welded machine frame with high rigidity for a precise cut
- Super Cut scoring unit guarantees smooth edges and a perfect quality for the following edging procedure.
- Version for composite panels, i.e. Alucobond
- Automatic version 1260 for high productivity

CUT 1280

- The vertical sawing centre
- Automatic positioning
- Unique – with hardened linear guide ways
- Perfectly equipped for outright precision



EDGE BANDERS

High-tech for perfect edges

The edge bander is crucial for the high-end look of your furniture. Benefit from more than 45 years of HOLZ-HER technological leadership in edge banding.

ARCUS 1336

- Various service packages
- Over 30 aggregates tuned to your application profiles
- Up to 20 NC-servo axes fully automated
- Easy programming



CONTRIGA

- High-end edge banding in peak perfection
- High performance with award-winning industrial design
- Customized – perfectly equipped in any application range



HOLZ-HER Glu Jet

with hybrid technology

In all HOLZ-HER edge banders as standard

- **New:** now with 3 years warranty
- **Extremely efficient:**
heat up time only 3,5 minutes
- **Always 100% glue power:**
only the glue quantity needed will be melted
- **Outright precise:**
toothed glue application with almost invisible glue line
- **Unique – with hybrid technology:**
 - application of glue granules and cartridges
 - application of PUR and EVA glue types
 - application of different glue colours

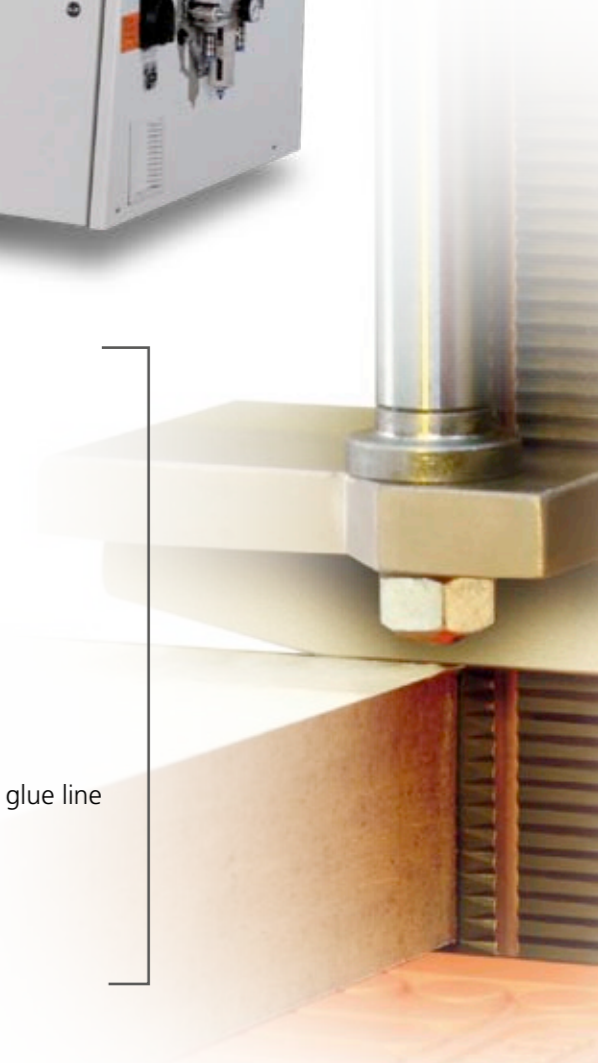

EDGE BANDERS

Predominant competence in edge banding

Concentrating on essentials HOLZ-HER edge banders are combining a compact structure with a very high level of automation. Thereby HOLZ-HER set the standard for the modern carpenter.

- Compact and highly efficient at the same time
- Pre-milling unit for perfect edges
- Corner rounding units including diamond cutter
- Flexible glue application with **Glu Jet** hybrid technology – choice of glue cartridges or granules

Complete machining
of plastic and solid wood edges
More at www.holzher.com



AURIGA 1304

- Compact, easy and powerful up to 6 x 65 mm edge cross section
- Flexible glue application with **Glu Jet** hybrid technology
- Including pre-milling unit with 2 diamond cutters for perfect preparation of the panel edge before edge banding



Edge selection at the touch of a button –
without opening the hood

AURIGA 1308

- Power-PC control for easy programming and fast setting by means of NC-servo axes
- Highest automation level in its class
- NOW NEW: with cleaning package



SPRINT 1327

- Solid wood edges up to 12 mm edge thickness
- Feed speed variable up to 18 m/min.
- No post-treatment, best quality – selectively with EVA or with water and heat resistant PUR glues as standard

CNC-MACHINING CENTRES

Milling – Cutting – Drilling

Investing into state-of-the-art CNC technology is worth while. Even complicated designs in cabinetry and parts can be manufactured cost-effective and precise. Latest controller technology, digital drives and software of the newest generation open your shop to endless possibilities.

5-axis technology from HOLZ-HER
Strong. Flexible. Dynamic.
More at www.holzher.com



PRO-MASTER 7123

- Extreme acceleration and high dynamics at all axes for perfect results
- Utmost flexibility due to the modular design of all HOLZ-HER CNC-machines
- Precision ground and hardened linear guide ways with 10 year warranty on wear



PRO-MASTER 7225

- Five fully interpolating axes for top flexibility
- PRO-TORQUE-spindle for exceptional cutting quality
- Extreme precision through latest engineering
- Software package with integrated CabinetControl

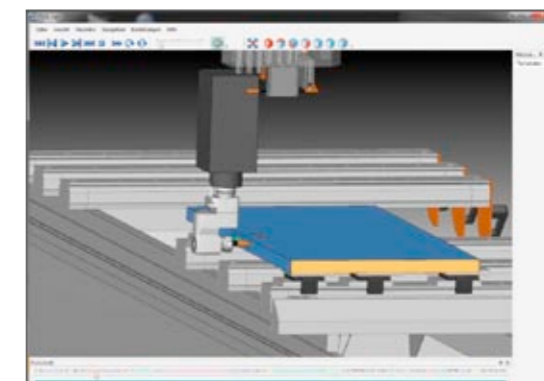

3D-cutting simulation with collision control (Option).

CNC-MACHINING CENTRES

CNC-technology made by HOLZ-HER

- Powerful digital synchro-drives for fast acceleration 11-kW (15 hp) spindle in the basic execution
- Ground and hardened linear guideways for absolute precision – with 10 year warranty on wear
- CAMPUS-software package with integrated CabinetControl module for easy creation of cabinets. Graphic display (Windows) for simple programming and use of the CNC-centres
- High productivity through digital workflow between beam saw, edge bander and CNC-machining centre



10 years warranty
On all linear guide ways of CNC-machines



State-of-the-art CNC technology
from HOLZ-HER

PRO-MASTER 7018

- Most powerful spindle in its class – 11-kW (15 hp)
- 4-field machining with up to 1250 mm capacity in Y and 180 mm workpiece height
- The reference for cost-effective CNC-manufacturing

DYNESTIC 7515

- Perfection in nesting technology
- Nesting table with extreme high vacuum flow
- Dynamic movements of all axes for perfect results



True-shape-nesting software with the powerful nesting module from HOLZ-HER. Incl. List-and-Label function for barcode printing.



Even more effective with auto-feeding

The work piece is pulled from in-feed roller beams [1] onto the machine table [2] using vacuum cups that are mounted to the gantry. After the nesting process a pusher brings the nested parts onto the conveyor belt of the out-feed table [3].

DYNESTIC 7521

- High end nesting
- Dimensions of up to 6250 mm x 2100 mm (20' 6" x 6' 10")
- Variable loading and feeding options



ALSO WITH NESTING

A well rounded affair

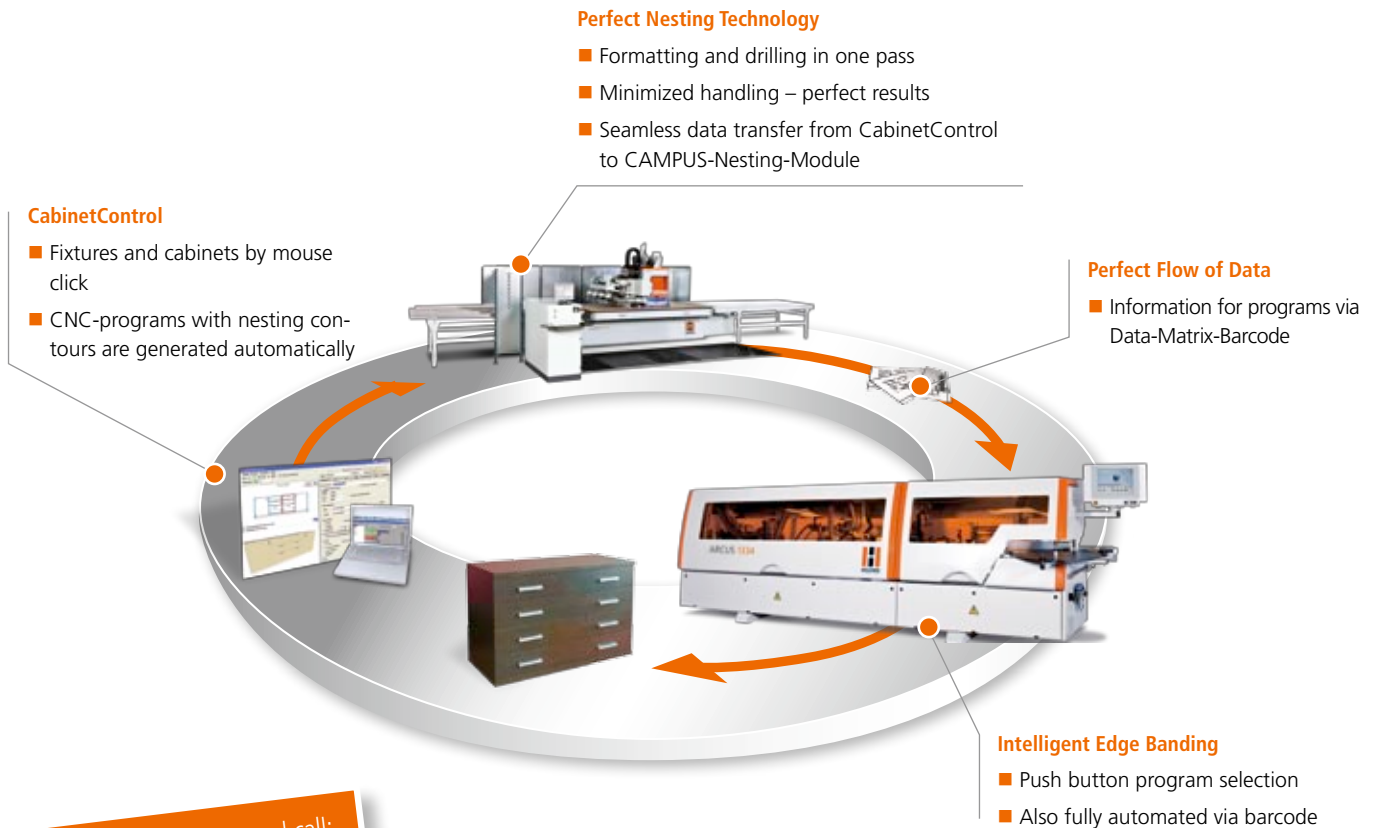

For detailed information and to enrol call:
+49 (0) 7022 702 216

We are looking forward to seeing you!

In house show at HOLZ-HER

October 06. – 08. 2011

in Nürtingen / Germany

October 06, 9.00 am – 6.00 pm

October 07, 9.00 am – 6.00 pm

October 08, 9.00 am – 3.00 pm



See innovations live on 2000 sqm

HOLZ-HER Showroom

Seilerstrasse 6
72622 Nürtingen / Germany
Email: hausmesse@holzher.com
Phone: + 49 (0) 7022 702 216

Directions:
www.holzher.com

Contact your HOLZ-HER dealer.



HOLZ-HER GmbH
Plochinger Strasse 65
72622 Nürtingen / Germany
Phone: + 49 7022 702 0
Fax: + 49 7022 702 101
www.holzher.com

A member of
the WEINIG Group